

Selected examples of customised gears

Lightweight gear based on CPL-2A Gear Component Set

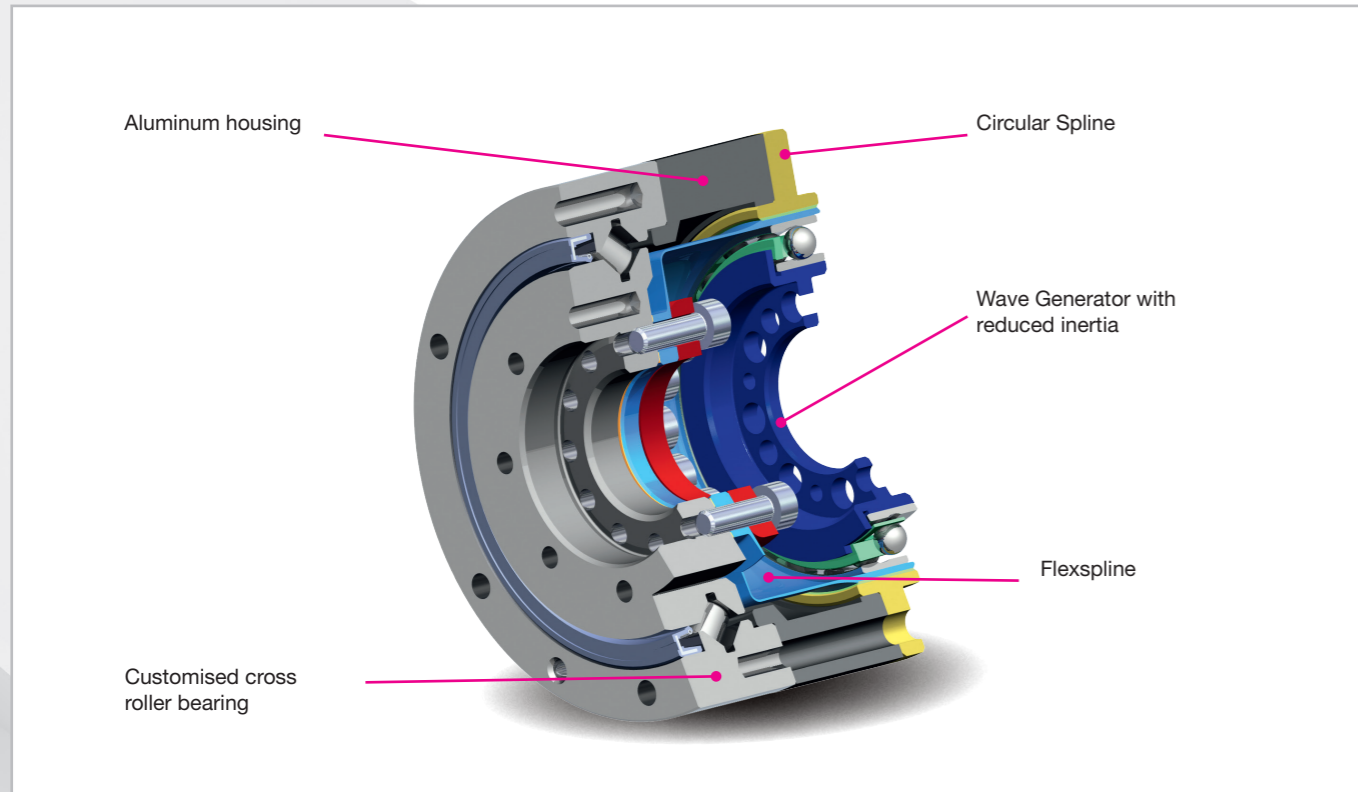

Swivel joint for X-ray system based on the SHG-2UH Hollow Shaft Gear, bevel gear pre-stage and a toothed belt pre-stage

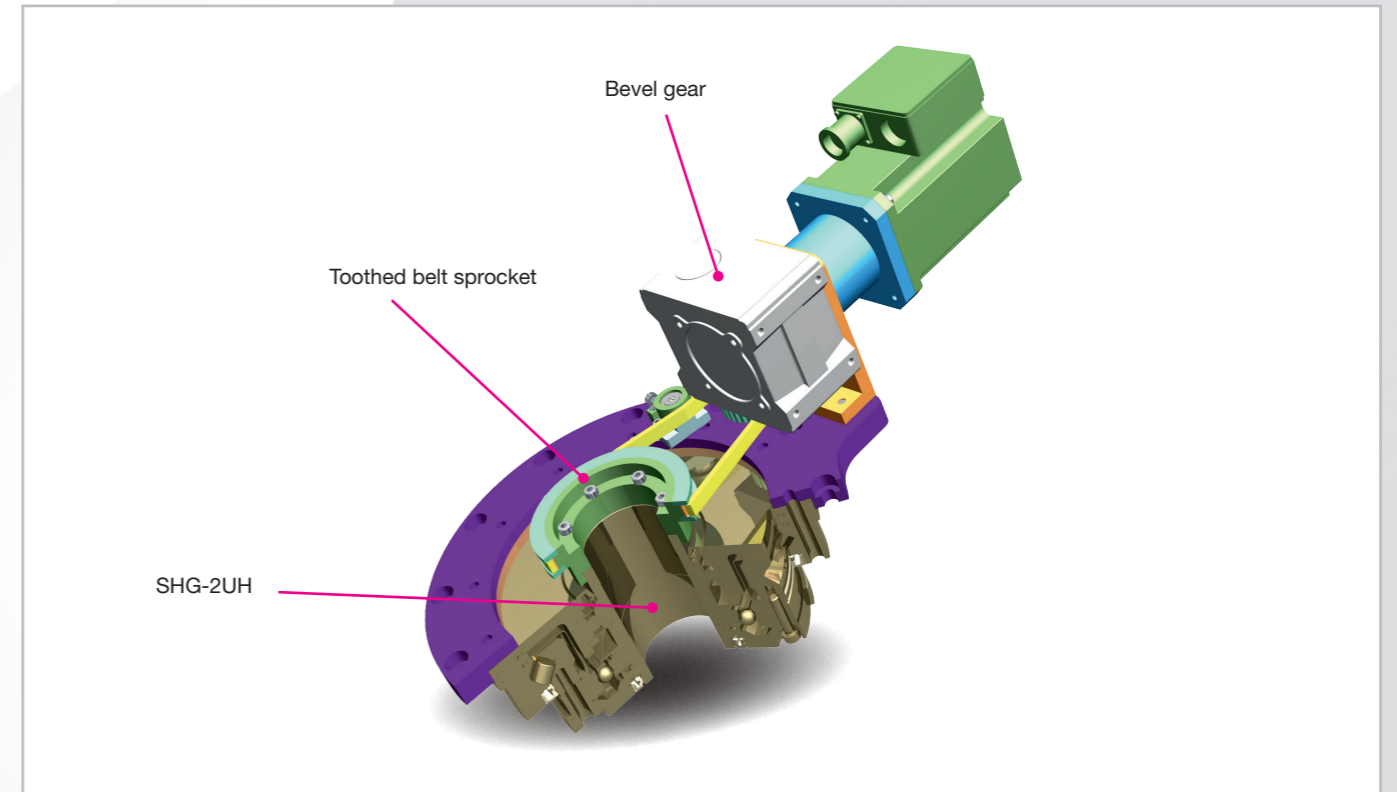

Gear for robotic axis with customised hollow shaft for adaptation of rotor magnets, encoder and brake

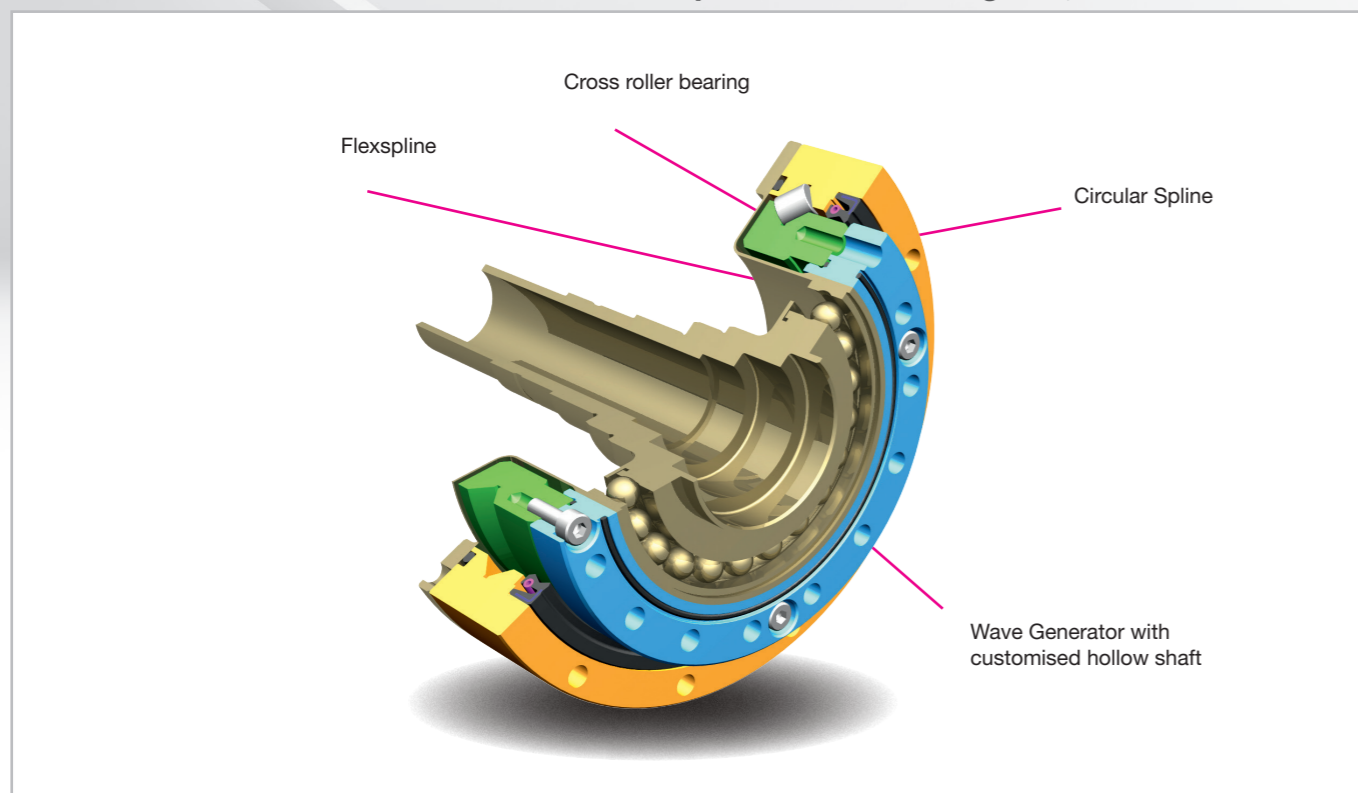

Two SCARA robot axes based on SHG-2SO with motor adaptation

